

Technical Specification

Model	PIC-4202
Display	UPPER:- 4 Digit 7 seg .39",red LED Display LOWER:- 4 Digit 7 seg .28",green LED Display
Size	48 X 48 X 95
Panel Cutout	44 X 44
Input	0 To 10V DC,4 To 20mA DC,0 To 20mA DC
Range	-.999 To 9999 Selectable
Output	2 Relay 1C/0
Transmitter Supply	24V DC
Power Supply	100 to 250V AC (SMPS)

Key Operations

- 1) Press Key to enter in parameter menu.
- 2) Press Key to go to next parameter.
- 3) Use Or key to change value of parameter.
- 4) Press Key to save change in setting

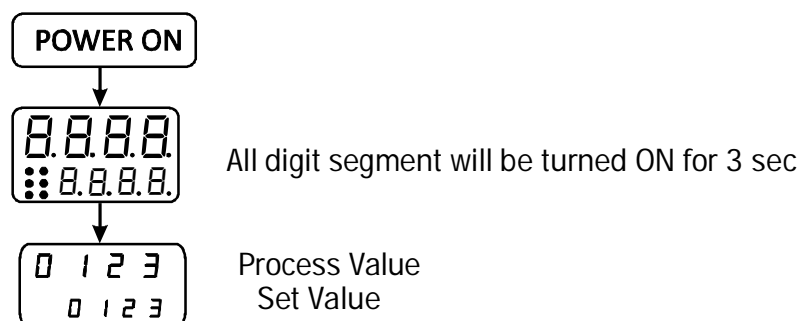

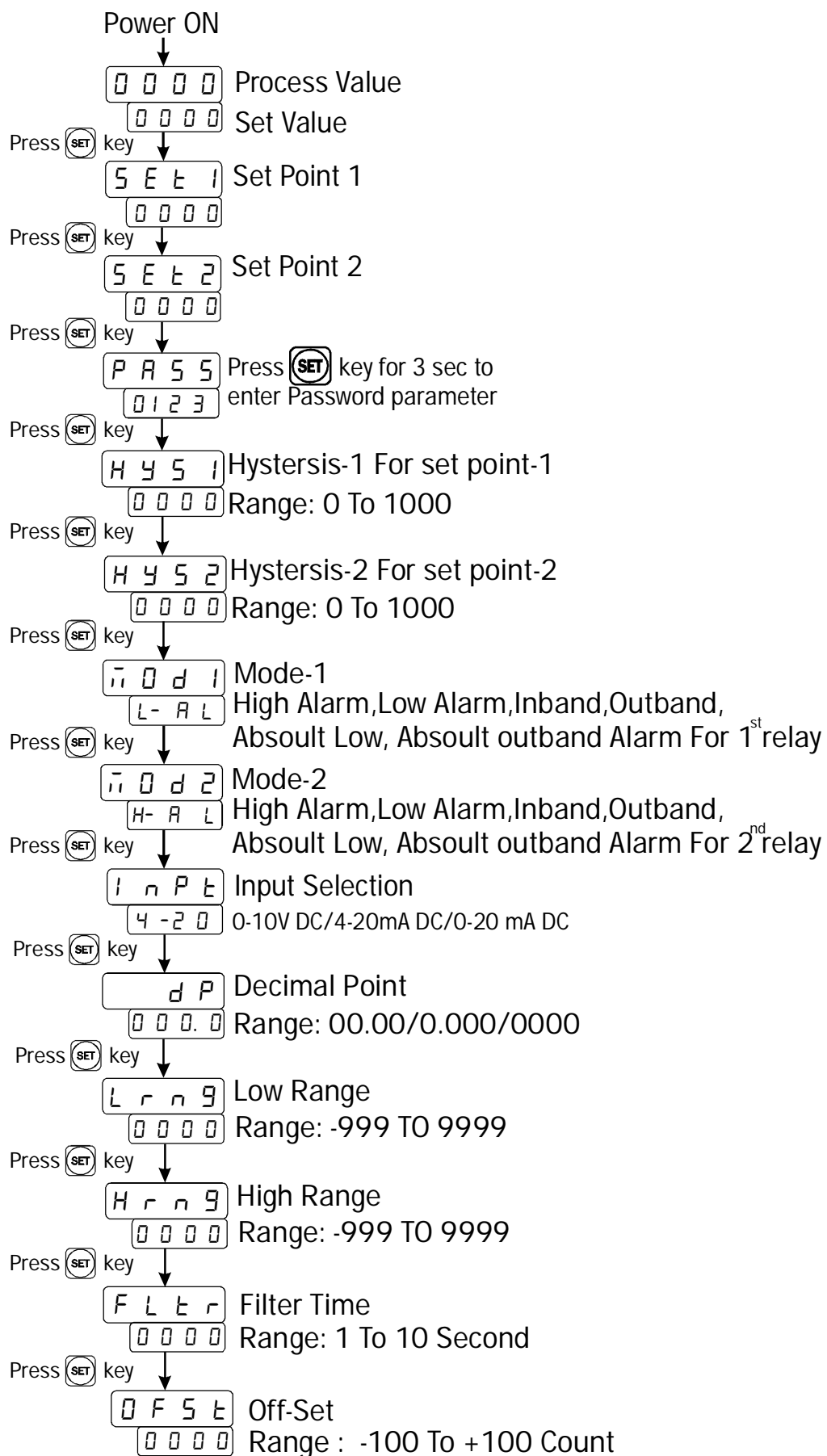

USER CONFIGURATION

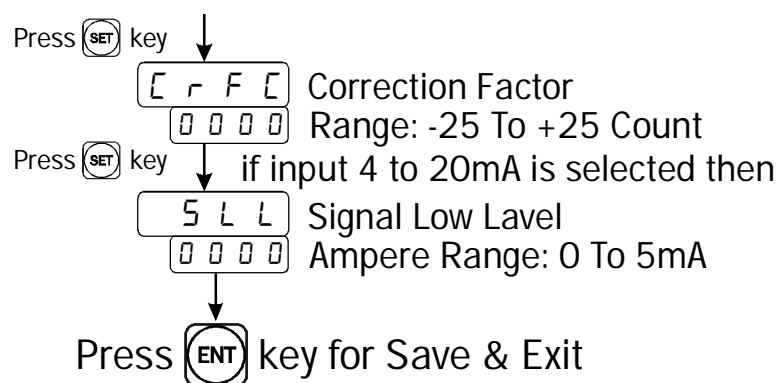



Working

- 1). Do all connection as shown in connection diagram and turn on the instrument.
- 2). Display will indicates process value according to 4-20mA input available and according to decimal point.
- 3). The Range Corresponding to 4-20mA is selectable from keypad.
- 4). If high range is to select 9999 then at 20mA input the display will show 9999 & if low range is to select 0000 then at 4mA input the display will show 0000.
- 5). In Low Alarm (For Mode-1),Initially relay-1 will be on condition. When Process value equals (Set-1 + Hys-1) relay-1 will turn off. When process value equal set point-1 then again relay-1 will be on.
- 6). In High Alarm (For Mode-1),Initially relay-1 will be off condition. When Process value equals set point-1 relay-1 will turn on. When process value equal set 1- Hys 1 then again relay-1 will be off.
- 7). In Band Alarm (For Mode-1),Relay-1 will be on between Set point-1 & Hys-1 condition.
- 8). Out Band Alarm (For Mode-1),Relay-1 will be off between Set point-1 & Hys-1 condition.
- 9). Absolute Low Alarm (For Mode-1), Initially Relay-1 will be off. When first time process value equals (Set-1 + Hys-1) then relay-1 will be on. Again process value below Set point-1 relay remains on.
- 10). Absolute Out Band Alarm, Initially relay will be off. When first time process value is in between Set point-1 & Set point-2 relay will be on. Now, Process value is below Set point-2 & Above Set point-1 relay remains off.
- 11). If the input is not connected Display will show OPEN.
- 12). When Input Exceeds the full scale Range (Approx above 20mA) then Display will show  (OVER).
- 13). When input is lower than 4mA (Signal Low Level Range: 0 To 5mA) then Display will show  (LOW).

Connection Diagram

